



PTU-M

High Precision Pan-Tilt Unit for Various Applications.

PTU-M is the medium-size PAN-TILT solution in HEVI Optronics portfolio. PTU-M is a fully ruggedized assembly for applications, where precision and reliability are crucial.

The system is designed to be used as an electro-optical sensor platform, but is suitable for antenna tracking and many other applications as well. Optional Gyro-Stabilization provides long range surveillance capability using customers own sensor package.

The system is designed to enable the use of field swappable sensor modules for various demanding applications. Telescope and laser system integrations are possible, as well as options to create 24/7 covert surveillance solutions.

APPLICATIONS

- Electro-Optical sensor platform
- Antenna tracking
- Target designation
- Rangefinding
- Drone detection

KEY FEATURES

- Extremely rigid frame design
- Zero-backlash system
- Gyro-stabilized
- Additional pass-through connections
- Ruggedised according MIL-STDs
- Continuous 360 azimuth movement, -45 to +45 degree elevation range
- Internal Gigabit Ethernet router or switch with top module connectivity
- EMI filtered internal 24VDC or 48VDC power

PTU-M Specifications

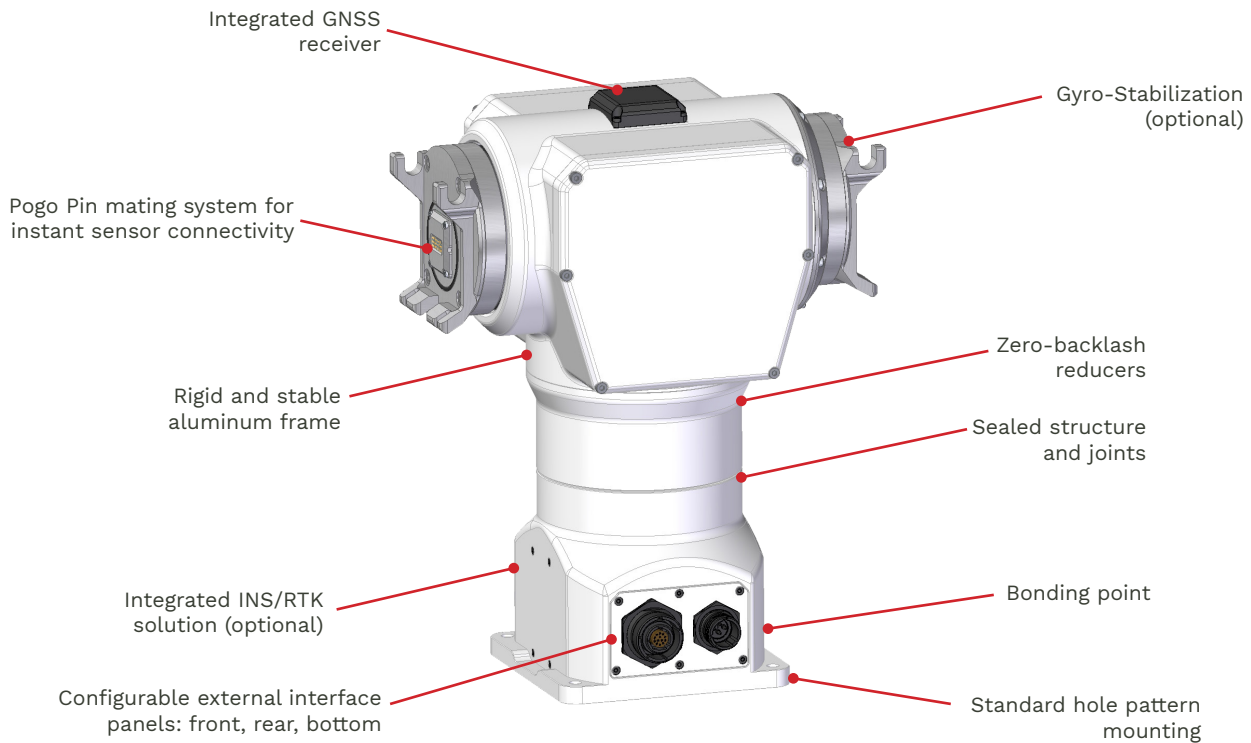

PTU-M features

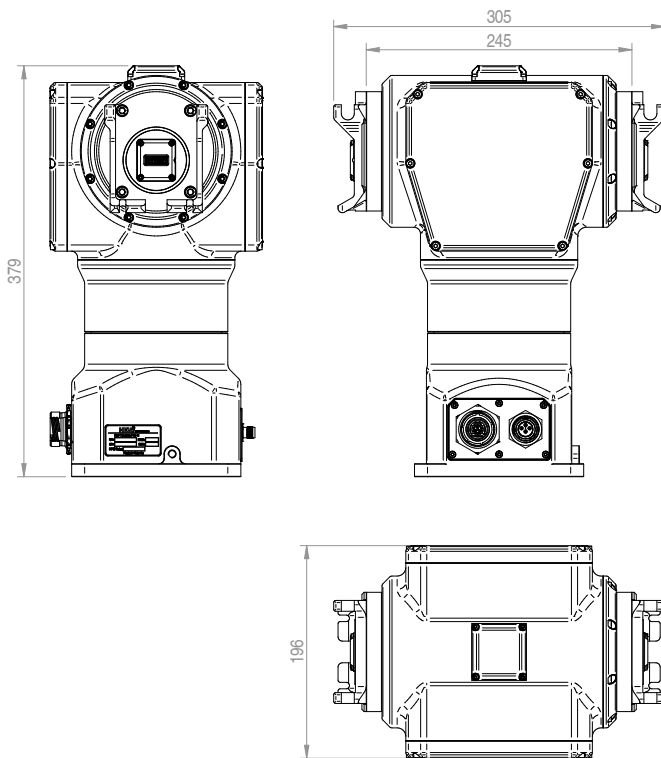

PTU-M dimensions

GENERAL CHARACTERISTICS OF 2-AXIS ASSEMBLY:

Azimuth Range	360° continuous rotation
Elevation Range	-45° to +45° (standard configuration, can be extended)
Slew rate	Max 60°/sec Min 0.002°/sec
Positioning accuracy	0.0005°
Payload capacity	25 + 25 kg, top payload adapter optional
Gyro-stabilization	PTU-M, no PTU-M+, yes

ENVIRONMENTAL CONDITIONS: *(Designed to be compatible)*

Environmental	Sealed to IP65 / MIL-STD-810H
Electrical	MIL-STD-1275 DEF-STAN 61-5
Operating temperature	- 40° to +70°C
Mechanical Protection	Rigid Aluminium housing

PHYSICAL AND ELECTRICAL CHARACTERISTICS

Mass	15.0 kg
Dimensions	380 H x 245 W x 196 L with integrated GNSS receiver
Input Voltage	12-36 VDC, 48 VDC option available
Power Consumption	60 W average 100 W typical when moving under load 200 W peak at max torque rating
Control Interface	Gigabit Ethernet (standard) Serial (RS232, RS422 optional)
Available on-board power	300 W

OTHER FEATURES:

Integrated GNSS receiver on top
Integrated Dual Antenna GNSS-Aided INS in base (Optional)
Host platform INS integration possibility
Custom cable assemblies available



PTU-M usage example